

PART NUMBER : MAEHWBRICK			REVISION LEVEL :
Amendment	Date	By	TOLERANCES :
			Decimal Places: 0 ± 0.5
			0.0 ± 0.2
			Angles Degrees: 0 ± 5°

MINOS BRICK LAYOUT			
ITEM	PART ID	DESCRIPTION	QUANTITY
1	MIC00354	MIC BRICK	6
2	MIC00355	MIC BRICK HALF	1
3	MICAC109	MIC BAFFLE SUB ASSEMBLY	1
4	HBA00118	HBA BRICK RETAINER	7

BRICK INSTALLATION:
 (1) LOOSEN BRICK RETAINER SCREWS WITH 10MM SPANNER
 (2) POSITION BRICKS AS PER BRICK LAYOUT
 (3) TIGHTEN BRICK RETAINER SCREWS

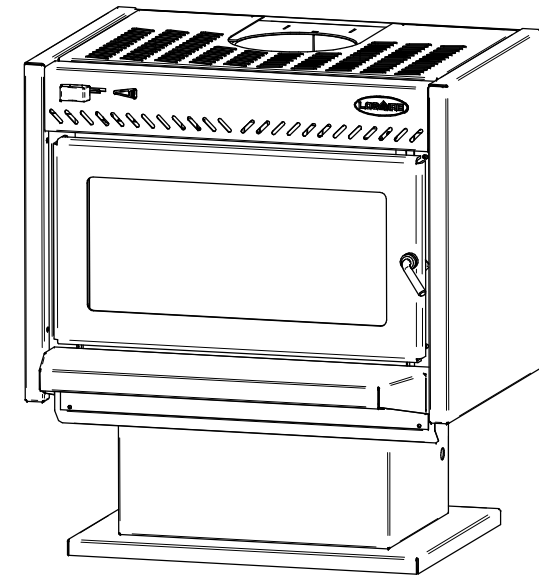
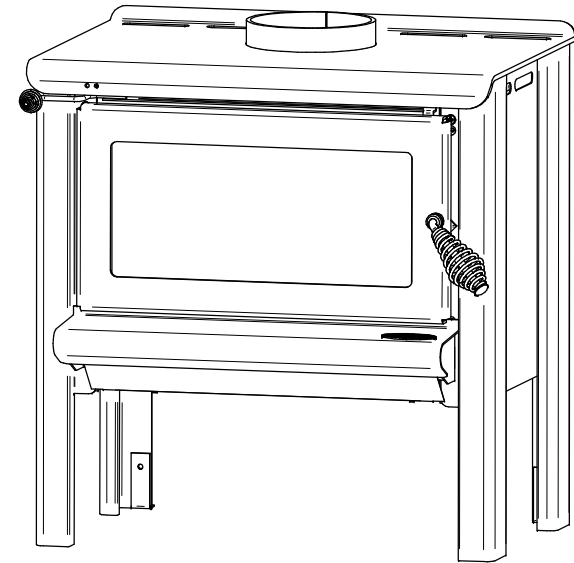
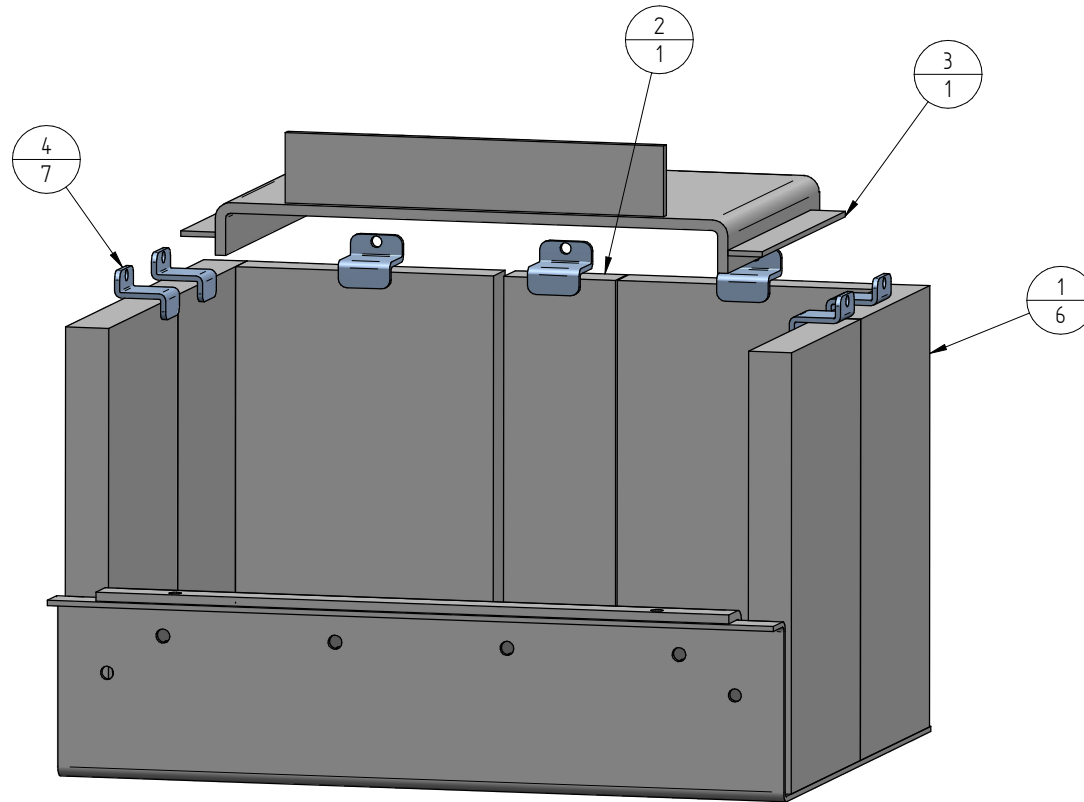

BRICK & BAFFLE LAYOUT FOR AUSTRALIAN MICROS AND MINOS HARDWOOD MODELS

Weight = 70.484 kg

GLEN DIMPLEX AUSTRALASIA LTD
 38 HARRIS ROAD, EAST TAMAKI, AUCKLAND, NEW ZEALAND
 Ph 09 274 8265, Fax 09 274 8472, Email : Eng_Office@glendimplex.co.nz

Customer : LOGAIRE	Drawing No :	Drawn : davidl	Date : 16-03-07	Chk'd By :
		Modified : prakashs	Date : 30-03-11	
Part Name: MINOS HW & MICROS HW BRICK LAYOUT		Material :	Finish : Natural	